

Danair AUTOMATIC HAMMER® Parts Diagram: Models AH-15-PF & AH-15-PF-9000

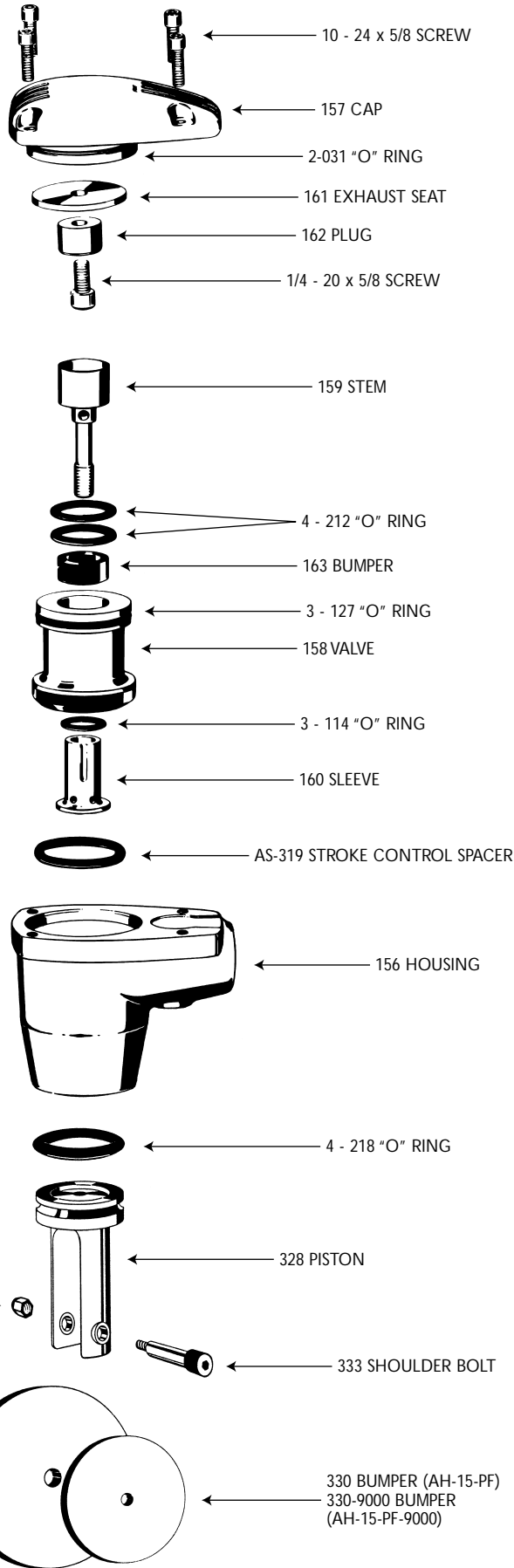

DANAIR INC.

2180 Pinion Rd. Suite F
Elko, NV. 89801-8829 USA

LIMITED LIFETIME WARRANTY

Any part which is determined by DANAIR to be defective in material or workmanship and returned to DANAIR, Elko, NV, shipping cost prepaid, will be repaired or replaced at DANAIR'S option. This warranty does not apply to normal wear or damage resulting from accident, alteration or use otherwise than recommended by DANAIR. Any liability for consequential and incidental damages is expressly disclaimed. DANAIR'S liability in all events is limited to, and shall not exceed, the purchase price paid for the DANAIR product.