

Danair AUTOMATIC HAMMER® Parts Diagram

CAP ASSEMBLY

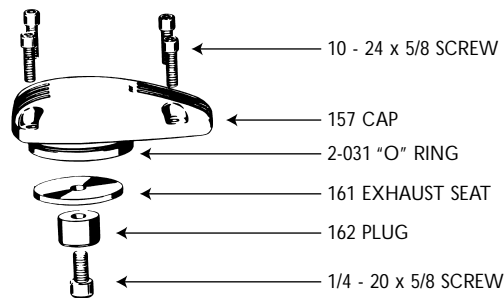

HAMMER TIP and VALVE ASSEMBLY

AS-319 STROKE CONTROL SPACER
(available as optional accessory)
SHORTENS STROKE AND
REDUCES HAMMERING FORCE

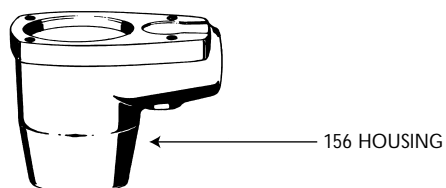
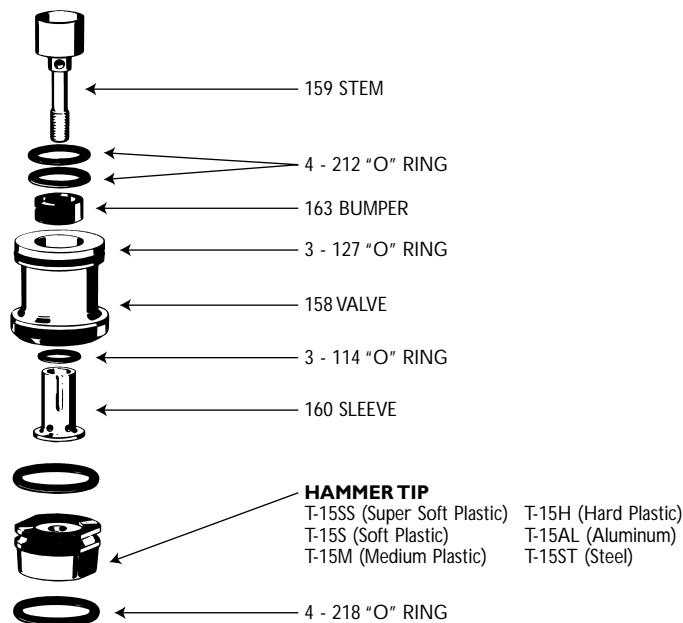

CHANGING HAMMER TIPS

STEP No. 1

Remove cap and slide out hammer tip and valve assembly. Remove O-ring from hammer tip.

STEP No. 2

Hold hammer tip with wrench (or in vise) and use 1/4 hex wrench to remove (or install) hammer tip.

NOTE: Tighten assembly securely when installing hammer tip.

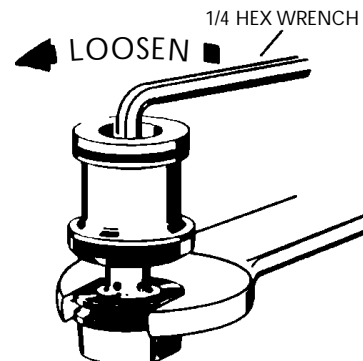

LIMITED LIFETIME WARRANTY

Any part which is determined by DANAIR to be defective in material or workmanship and returned to DANAIR, Elko, NV, shipping cost prepaid, will be repaired or replaced at DANAIR'S option. This warranty does not apply to normal wear or damage resulting from accident, alteration or use otherwise than recommended by DANAIR. Any liability for consequential and incidental damages is expressly disclaimed. DANAIR'S liability in all events is limited to, and shall not exceed, the purchase price paid for the DANAIR product.

PM-AH-190

Revision "A" 4-1-00

DANAIR INC.

2180 Pinion Rd. Suite F
Elko, NV 89801-8829 USA

Printed in the U.S.A.